

DWDM Directly Modulated DFB Laser Module for Narrowcasting

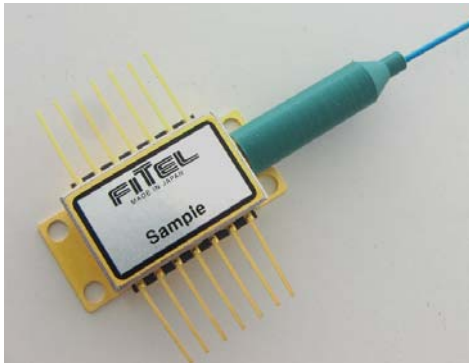

Applications

- Narrowcasting
- DWDM transmission

Descriptions

FRL15DDAx-A31-xxxxx series of DFB laser module is designed for narrowcast application in CATV systems. The modules provide high output power while maintaining high linearity. The modules are housed in an industry standard hermetically sealed 14-pin butterfly package, which contains optical isolator, thermoelectric cooler, and power monitor photodiode.

Features

- Industry standard OC-48 pin compatibility
- High fiber-coupled power, up to 12mW
- ITU standard wavelengths
- RoHS compliant package

Absolute Maximum Ratings

Parameter	Symbol	Min	Max	Unit	Conditions
Storage Temperature	Tstg	-40	85	°C	-
Operating Case Temperature	Tc	-20	70	°C	-
LD Reverse Voltage	V _{rLD}	-	2	V	-
LD Forward Current	I _{fLD}	-	150	mA	-
PD Reverse Voltage	V _{rPD}	-	20	V	-
PD Forward Current	I _{fPD}	-	5	mA	-
TEC Current	I _{tec}	-	1.6	A	-
TEC Voltage	V _{tec}	-	2.6	V	-

Specifications (TLD=Tset, Tc=25°C, unless otherwise specified)

Parameter	Symbol	Min	Typ	Max	Unit	Conditions
Optical Output Power	Pf	8	-	12	mW	CW, If=Iop
LD Forward Current	If	-	-	80	mA	CW, BOL
LD Forward Voltage	Vf	-	-	2.0	V	CW
Threshold Current	I _{th}	-	10	20	mA	BOL
Submount Temperature	Tset	20	-	35	°C	If=Iop, CW
Slope Efficiency	η	0.14	0.20	0.35	W/A	CW, If=Iop
Input Impedance	Zin	-	25	-	Ω	
Wavelength	λ	λ _{ITU} -0.1	λ _{ITU}	λ _{ITU} +0.1	nm	If=Iop, CW, λ=1527.22~1610.06, See Table.1
Optical Isolation	ISO	30	-	-	dB	
Side Mode Suppression Ratio	SMSR	35	45	-	dB	CW, If=Iop
Cut-off Frequency	fc(-1.5dB)	2	3	-	GHz	If=Iop
	fc(-3dB)	3	4	-	GHz	If=Iop
Frequency Response	S21	-	-	±0.5	dB	If=Iop, f=45 to 860MHz
2nd Order Distortion	IMD2	-	-	-35	dBc	2 tone test, If=Iop f1=553.25MHz, f2=595.25MHz, OMI=35%/tone, SMF 50km
3rd Order Distortion	IMD3	-	-	-44	dBc	2 tone test, If=Iop f1=553.25MHz, f2=595.25MHz, OMI=35%/tone, SMF 50km
Relative Intensity Noise	RIN	-	-	-155	dB/Hz	CW, If=Iop, f=45 to 860MHz
Monitor Current	I _m	0.05	-	2	mA	CW, If=Iop, V _{rPD} =5V
Monitor Dark Current	I _d	-	-	100	nA	V _{rPD} =5V
Tracking Error	TE	-0.5	-	0.5	dB	I _m =constant, Tc = -20 to 70°C
TEC Current	I _{tec}	-	-	1.2	A	Tc=70°C, CW, If=Iop
TEC Voltage	V _{tec}	-	-	2.4	V	Tc=70°C, CW, If=Iop
Thermistor B constant	B	-	3900	-	K	
Thermistor Resistance	R	9.5	-	10.5	kΩ	Tset=25°C

Optical Fiber Pigtail Specifications

Parameter	Specification	Unit
Fiber Type	Corning SMF-28 or equivalent Flame Retardant Hytrel Coating 0.9mmφ	-
Nominal Fiber Length	Min. 1,000 (Boot edge (fiber side) to connector edge)	mm
Connector Type	SC/SPC Connector	-

Dimensions and Pin Assignments

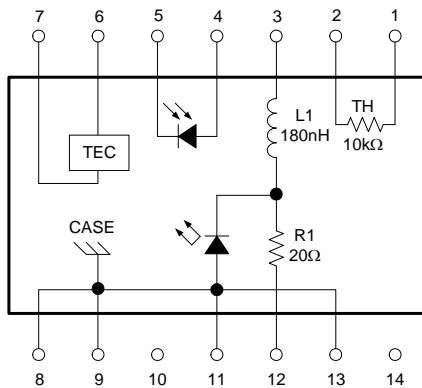
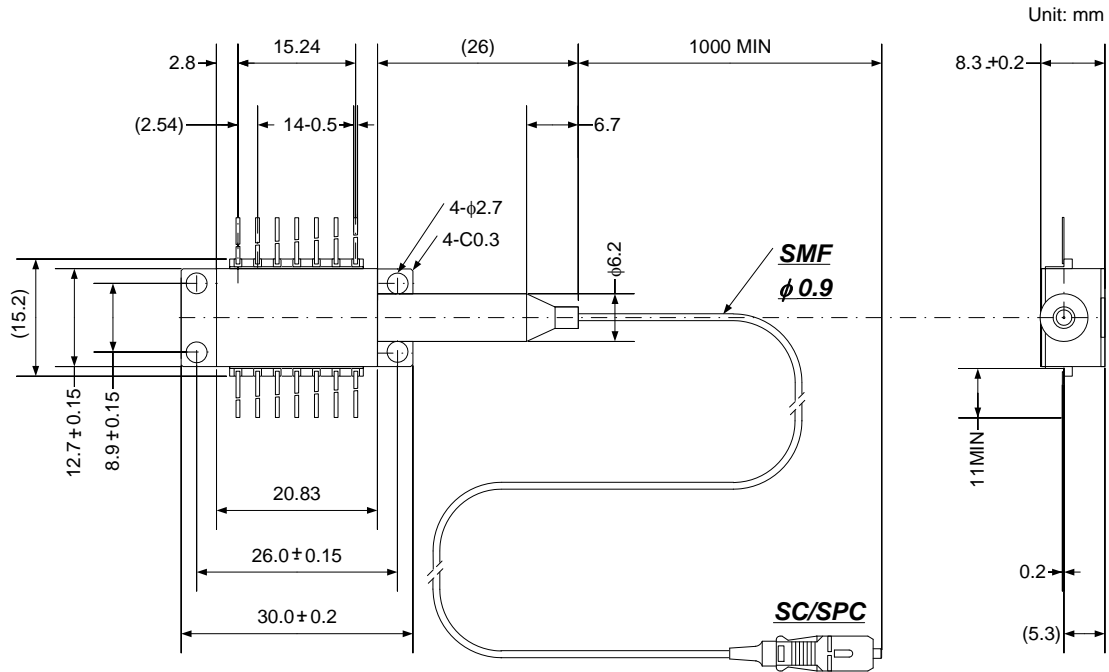

PIN No.	Object	PIN No.	Function
1	Thermistor	8	Case Ground
2	Thermistor	9	Case Ground
3	LD Cathode(-)	10	No Connect
4	Monitor Anode(-)	11	Laser Anode(+), Case Ground
5	Monitor Cathode(+)	12	Laser RF
6	TEC(+)	13	Laser Anode(+), Case Ground
7	TEC(-)	14	No Connect

Table 1

λ [nm]	ITU Freq. [THz]	λ Code	λ [nm]	ITU Freq. [THz]	λ Code	λ [nm]	ITU Freq. [THz]	λ Code	λ [nm]	ITU Freq. [THz]	λ Code
1527.22	196.30	19630	1547.32	193.75	19375	1567.95	191.20	19120	1589.15	188.65	18865
1527.61	196.25	19625	1547.72	193.70	19370	1568.36	191.15	19115	1589.57	188.60	18860
1527.99	196.20	19620	1548.12	193.65	19365	1568.77	191.10	19110	1589.99	188.55	18855
1528.38	196.15	19615	1548.52	193.60	19360	1569.18	191.05	19105	1590.41	188.50	18850
1528.77	196.10	19610	1548.92	193.55	19355	1569.59	191.00	19100	1590.83	188.45	18845
1529.16	196.05	19605	1549.32	193.50	19350	1570.01	190.95	19095	1591.26	188.40	18840
1529.55	196.00	19600	1549.72	193.45	19345	1570.42	190.90	19090	1591.68	188.35	18835
1529.94	195.95	19595	1550.12	193.40	19340	1570.83	190.85	19085	1592.10	188.30	18830
1530.33	195.90	19590	1550.52	193.35	19335	1571.24	190.80	19080	1592.52	188.25	18825
1530.73	195.85	19585	1550.92	193.30	19330	1571.65	190.75	19075	1592.95	188.20	18820
1531.12	195.80	19580	1551.32	193.25	19325	1572.06	190.70	19070	1593.37	188.15	18815
1531.51	195.75	19575	1551.72	193.20	19320	1572.48	190.65	19065	1593.79	188.10	18810
1531.90	195.70	19570	1552.12	193.15	19315	1572.89	190.60	19060	1594.22	188.05	18805
1532.29	195.65	19565	1552.52	193.10	19310	1573.30	190.55	19055	1594.64	188.00	18800
1532.68	195.60	19560	1552.93	193.05	19305	1573.71	190.50	19050	1595.07	187.95	18795
1533.07	195.55	19555	1553.33	193.00	19300	1574.13	190.45	19045	1595.49	187.90	18790
1533.47	195.50	19550	1553.73	192.95	19295	1574.54	190.40	19040	1595.91	187.85	18785
1533.86	195.45	19545	1554.13	192.90	19290	1574.95	190.35	19035	1596.34	187.80	18780
1534.25	195.40	19540	1554.54	192.85	19285	1575.37	190.30	19030	1596.76	187.75	18775
1534.64	195.35	19535	1554.94	192.80	19280	1575.78	190.25	19025	1597.19	187.70	18770
1535.04	195.30	19530	1555.34	192.75	19275	1576.20	190.20	19020	1597.62	187.65	18765
1535.43	195.25	19525	1555.75	192.70	19270	1576.61	190.15	19015	1598.04	187.60	18760
1535.82	195.20	19520	1556.15	192.65	19265	1577.03	190.10	19010	1598.47	187.55	18755
1536.22	195.15	19515	1556.56	192.60	19260	1577.44	190.05	19005	1598.89	187.50	18750
1536.61	195.10	19510	1556.96	192.55	19255	1577.86	190.00	19000	1599.32	187.45	18745
1537.00	195.05	19505	1557.36	192.50	19250	1578.27	189.95	18995	1599.75	187.40	18740
1537.40	195.00	19500	1557.77	192.45	19245	1578.69	189.90	18990	1600.17	187.35	18735
1537.79	194.95	19495	1558.17	192.40	19240	1579.10	189.85	18985	1600.60	187.30	18730
1538.19	194.90	19490	1558.58	192.35	19235	1579.52	189.80	18980	1601.03	187.25	18725
1538.58	194.85	19485	1558.98	192.30	19230	1579.93	189.75	18975	1601.46	187.20	18720
1538.98	194.80	19480	1559.39	192.25	19225	1580.35	189.70	18970	1601.88	187.15	18715
1539.37	194.75	19475	1559.79	192.20	19220	1580.77	189.65	18965	1602.31	187.10	18710
1539.77	194.70	19470	1560.20	192.15	19215	1581.18	189.60	18960	1602.74	187.05	18705
1540.16	194.65	19465	1560.61	192.10	19210	1581.60	189.55	18955	1603.17	187.00	18700
1540.56	194.60	19460	1561.01	192.05	19205	1582.02	189.50	18950	1603.60	186.95	18695
1540.95	194.55	19455	1561.42	192.00	19200	1582.44	189.45	18945	1604.03	186.90	18690
1541.35	194.50	19450	1561.83	191.95	19195	1582.85	189.40	18940	1604.46	186.85	18685
1541.75	194.45	19445	1562.23	191.90	19190	1583.27	189.35	18935	1604.89	186.80	18680
1542.14	194.40	19440	1562.64	191.85	19185	1583.69	189.30	18930	1605.31	186.75	18675
1542.54	194.35	19435	1563.05	191.80	19180	1584.11	189.25	18925	1605.74	186.70	18670
1542.94	194.30	19430	1563.46	191.75	19175	1584.53	189.20	18920	1606.17	186.65	18665
1543.33	194.25	19425	1563.86	191.70	19170	1584.95	189.15	18915	1606.61	186.60	18660
1543.73	194.20	19420	1564.27	191.65	19165	1585.37	189.10	18910	1607.04	186.55	18655
1544.13	194.15	19415	1564.68	191.60	19160	1585.78	189.05	18905	1607.47	186.50	18650
1544.53	194.10	19410	1565.09	191.55	19155	1586.20	189.00	18900	1607.90	186.45	18645
1544.92	194.05	19405	1565.50	191.50	19150	1586.62	188.95	18895	1608.33	186.40	18640
1545.32	194.00	19400	1565.91	191.45	19145	1587.04	188.90	18890	1608.76	186.35	18635
1545.72	193.95	19395	1566.31	191.40	19140	1587.46	188.85	18885	1609.19	186.30	18630
1546.12	193.90	19390	1566.72	191.35	19135	1587.88	188.80	18880	1609.62	186.25	18625
1546.52	193.85	19385	1567.13	191.30	19130	1588.30	188.75	18875	1610.06	186.20	18620
1546.92	193.80	19380	1567.54	191.25	19125	1588.73	188.70	18870			

Wavelength values are referenced to vacuum.

Wavelength (λ) and ITU frequency (f) have a relationship as $\lambda[\text{nm}] = 299792458 / f[\text{THz}] / 1000$.

FITEL code is expressed as a 5 digit integer rounded from $100 \times f [\text{THz}]$.

Ordering Information

FRL15DDA□ – A31 – □□□□□

Optical output power
8:8mW
0:10mW
A:12mW

Wavelength Code

Safety Information

This product complies with 21 CFR 1040.10 and 1040.11, Class 3b laser product. Invisible laser radiation is emitted from the end of the fiber or connector. Avoid direct exposure to the beam.



Telcordia is a trademark of Telcordia Technologies, Inc.
ISO is a trademark of The International Organization for Standardization.
Hytel is a trademark of DuPont.

Furukawa Electric reserves the right to improve, enhance and modify the features and specifications of FITEL products without prior notifications.



FURUKAWA ELECTRIC CO., LTD.

Japan
Head Office
 2-2-3, Marunouchi
 Chiyoda-ku
 Tokyo 100-8322, JAPAN
 Tel: +81-3-3286-3253
 Fax: +81-3-3286-3978
<http://www.furukawa.co.jp>
 Email:comsales@ho.furukawa.co.jp

North America
OFS Fitel, LLC
Specialty Photonics Division
 25 Schoolhouse Road
 Somerset, NJ 08873 USA
 Tel: +1-732-748-7402
 Fax: +1-732-748-7436
<http://www.SpecialtyPhotonics.com>
 E-mail:info@SpecialtyPhotonics.com

Europe
Furukawa Electric Europe Ltd.
 3rd Floor, Newcombe House
 43-45 Notting Hill Gate
 London W11 3FE, UK
 Tel: +44-20-7221-6000
 Fax: +44-20-7313-5310
<http://www.furukawa-fitel.co.uk>
 E-mail:sales@furukawa-fitel.co.uk

ASIA
Furukawa Electric Hong Kong Ltd.
 Suite 2606, Shell Tower,
 Times Square, 1 Matheson Street,
 Causeway Bay, Hong Kong
 Tel: 852-2512-8938
 Fax: 852-2512-9717
<http://www.fehk.com.hk/>
 E-mail: guest@fehk.cn